

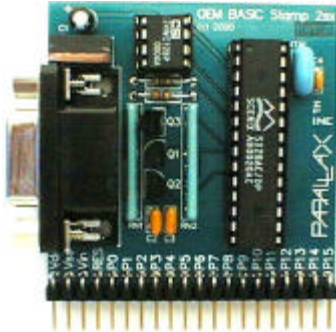



OEM BS2sx - Rev A Assembly Instructions

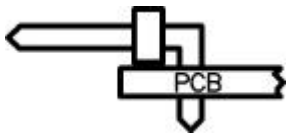
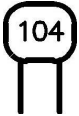

This document is a guide that will aid you in the assembly of your OEM-BS2sx. It is assumed that you have the proper equipment, and possess the skills necessary to safely assemble electronic components.

Generally, it is best to start with the lower profile components, and then work your way to the tallest components. This is often true because, in tight places, lower profile components are more difficult to get to with taller components in the way.

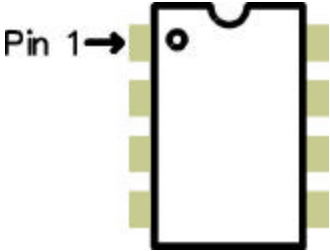
1. The two lowest profile components on the board are the 4.7K Ohm resistors. These resistors should have color bands around them which signify their value. The color band pattern should be: Yellow, Violet, Red, and Gold. Resistors are polarity insensitive, which means that it doesn't matter which end goes where. Install the resistors where designated by 'R1' and 'R2'.
 
2. The next lowest profile component on the board is the 20-pin right angle strip header. It may seem ambiguous as to which side is inserted into the pcb. The side with the angle should be inserted into the pcb as shown in the drawing to the right. Install the strip header where designated by 'X1'.
 
3. Next, find the two 0.1 uF ceramic capacitors. Like, the resistors, it doesn't matter which way these are installed. Install the two capacitors where designated by 'C2' and 'C3'.
 
4. The next component to look for is a small capacitor like C2 and C3 except that this one is a 5pF capacitor and is marked with a '5'. Install this capacitor where designated by 'C4'.
5. Next, find the resistor networks. A resistor network looks like a comb for a 'Barbie Doll'. On the resistor network (Rnet), there is a dot printed near one end to signify at which end Pin 1 is located. Find Pin 1 on the Rnet and correlate it to the square pad on the PCB that pertains to the 'RN1' part designator. Install the Rnets where designated by 'RN1' and 'RN2'.
 
6. The IC sockets are next in line. Nearly all ICs have a 'Pin 1' marker that denotes the location of Pin 1. It is important to install chips with the proper orientation since, more often than not, installing a chip backwards will result in damage to the chip and/or surrounding circuitry. For the IC sockets that you will be installing, there is a notch on the edge of one of the short sides. This notch denotes the 'top' of the chip. When oriented properly, Pin 1 is the top-left pin as depicted in the drawing to the right. Install both the 28-Pin and the 8-Pin DIP sockets into U1 and U2 respectively.
 

7. The next component to install is the ceramic resonator. The ceramic resonator looks like a coffee bean (although sometimes they are blue instead of brown) with three metal legs sticking out from one side and should be marked as "50.00" (50 MHz). This component is 'polarity insensitive'. That is to say that it doesn't matter which way it is installed, it will still work OK. Install the ceramic resonator where the 'XTAL' designator is.

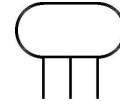

8. Next, grab the electrolytic capacitor. It resembles a small cylinder with two long legs emerging from one end. Be particularly careful when installing this component. If it is installed backwards, it can pop like a miniature fire cracker and emit a horrible stench after it is powered up. The electrolytic capacitor will have the negative lead marked with one or more '-' signs. Install the leg NOT marked with the '-' signs in the hole closest to the '+' sign in C1's space on the pcb.

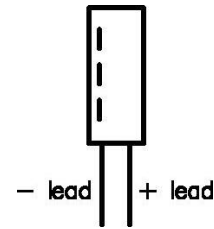

9. Now find the PNP transistor (Q3); it looks like a black bead with three legs and bears the mark, "3906". The white silkscreen on the pcb will guide you as to how to orient this component. There are two other components that closely resemble the PNP transistor that you will be installing in this step. Please note that the middle legs must be bent slightly to accommodate the hole patterns for Q1, Q2, and Q3. Please bend the middle leg of the PNP transistor (3906), and the NPN transistors, (3904), as shown in the drawing above. Avoid excessive bending as this can damage the component. Install the PNP transistor into Q3, and the NPN transistors into Q1, and Q2.

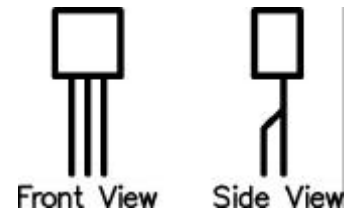

10. Next you will install the 9-pin D-Sub connector. This is the only component that looks like it will plug into a serial cable. Install it on the top side of the pcb.
11. The last component to solder on is the voltage regulator, VR1. It is a relatively large plastic square with a metal tab protruding from the top. Install this with the metal tab closest to the 9-pin D-Sub connector. This component, like the electrolytic capacitor, IS polarity sensitive and MUST be installed correctly, lest ye suffer smoke and fire and the gnashing of teeth.
12. Be sure you clean the board before you stuff the Basic Interpreter IC and the eeprom IC into U1's and U2's respective sockets. That's it ! You've done it! You've made your own stamp.
13. Visually inspect the board. Before applying power to it, repair any and all soldering errors and verify that all components have been installed in the proper locations and with the correct orientation.
14. Download and run the latest version of the program, STAMPW.exe, from either the CD or the website. Connect the OEM BS2sx to a PC serial port and power it up. Please consult the Basic Stamp manual, also available from either the CD or our website, for guidance on using your BS2sx. Please select the BS2sx as the default stamp before attempting to identify or download a program to your new BS2sx. You must also name the stamp program you wish to download with a .bsx extension.

OEM BS2sx – Rev A Design Notes

One of the main purposes behind the OEM BS2sx is making it easier to embed a BS2sx into an OEM design. When designing the BS2sx into an your product, please consider the following:

- **Power Supply** - The Basic Interpreter requires a 'clean' 5 Vdc supply. The LM2940 was selected because of its wide operating range, built-in protection features, and ability to deliver a lot of current. The value of the output capacitor, C1, was based on the manufacturer's recommendation. Be sure to consult the manufacturer's recommendations for input and output capacitance selection for the regulator that you will be using in your design. Also, if the Basic Interpreter will be located more than a couple of inches away from the power supply, it may be a good idea to add a 0.1 uF ceramic capacitor across Vdd and Vss at the Basic Interpreter IC.
- **Resonator Location** – Note that the resonator on the OEM BS2sx board is located adjacent to the Basic Interpreter. When laying out your board, please choose a location for the resonator that is as close as possible to the Basic Interpreter, and has the shortest circuit traces possible to ensure reliable operation.
- **Regulatory Warnings** – Stamps and their constituent components are not FCC approved. They are not in finished product form. If you wish to obtain FCC approval, you must first design the stamp into a product, then seek FCC approval of the whole product.

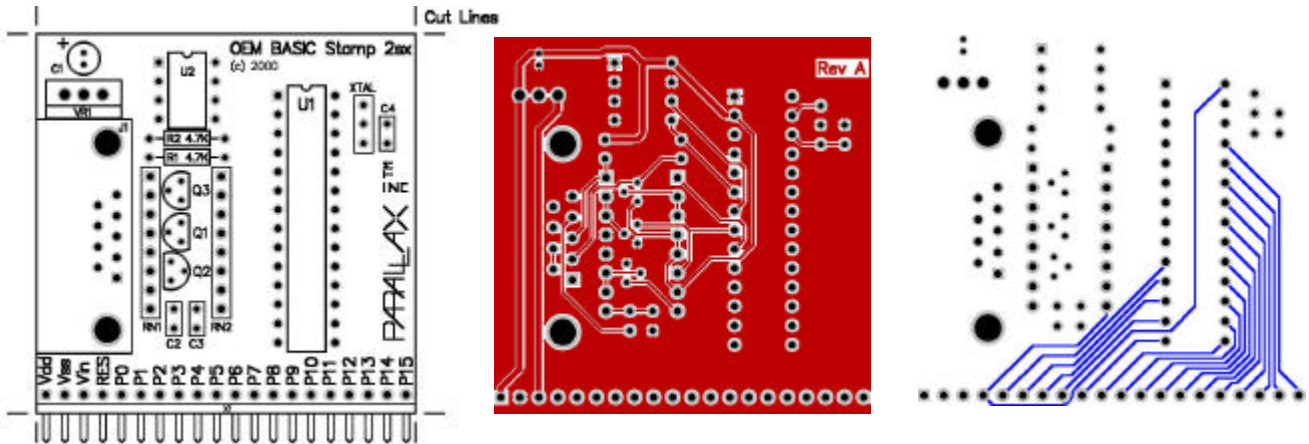

The above images of the board layers are not to scale. Please visit www.parallaxinc.com for the actual source and gerber files. This board was designed using Protel's Client '98 software. The top copper layer is the center plot, and the bottom copper layer is as 'viewed through' the board. The Rev A version of this board, depicted above, uses two layers. Of course, you may wish to use only one layer to reduce the cost of manufacturing. For that reason, we've provided a one-layer version of this design, Rev B, that is available from our website. The following schematic applies to both versions:

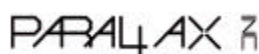
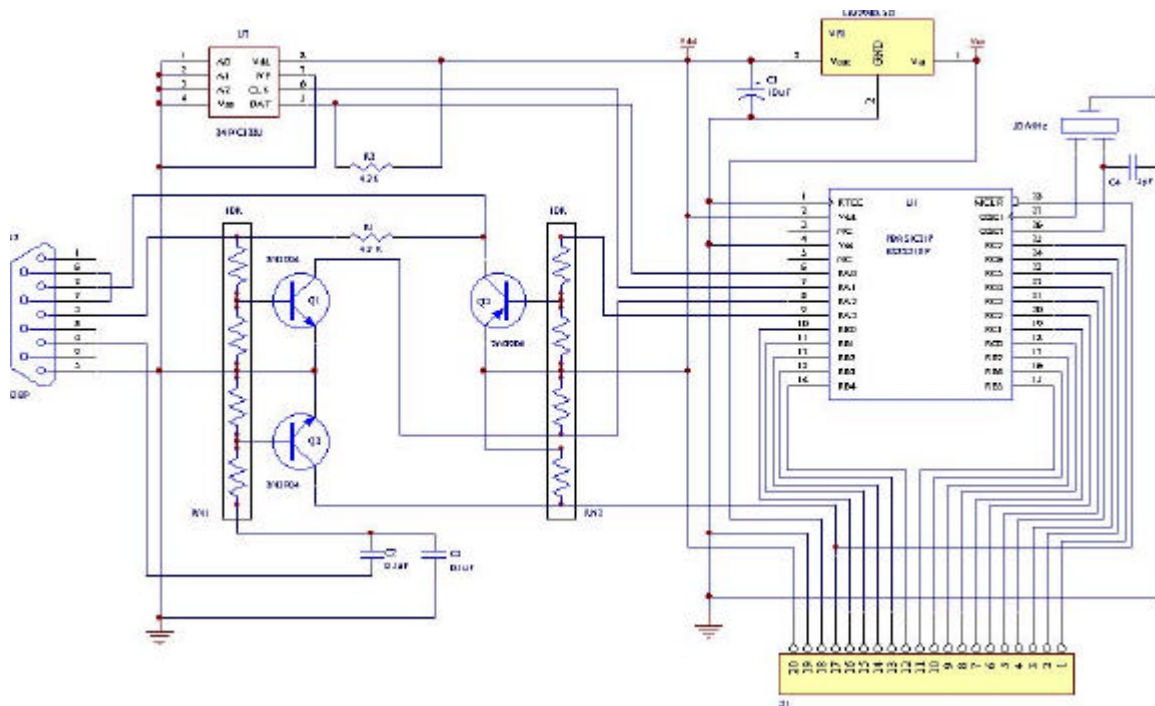

OEM BS2sx - Rev A Assembly Instructions

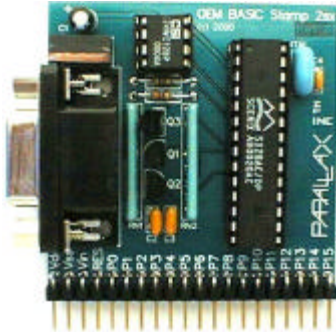

This document is a guide that will aid you in the assembly of your OEM-BS2sx. It is assumed that you have the proper equipment, and possess the skills necessary to safely assemble electronic components.

Generally, it is best to start with the lower profile components, and then work your way to the tallest components. This is often true because, in tight places, lower profile components are more difficult to get to with taller components in the way.

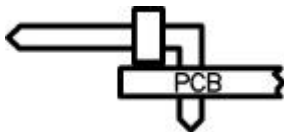
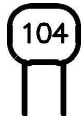
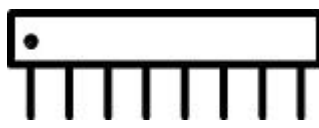
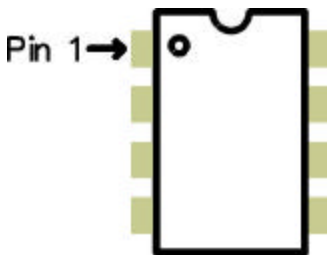
1. The two lowest profile components on the board are the 4.7K Ohm resistors. These resistors should have color bands around them which signify their value. The color band pattern should be: Yellow, Violet, Red, and Gold. Resistors are polarity insensitive, which means that it doesn't matter which end goes where. Install the resistors where designated by 'R1' and 'R2'.
 
2. The next lowest profile component on the board is the 20-pin right angle strip header. It may seem ambiguous as to which side is inserted into the pcb. The side with the angle should be inserted into the pcb as shown in the drawing to the right. Install the strip header where designated by 'X1'.
 
3. Next, find the two 0.1 uF ceramic capacitors. Like, the resistors, it doesn't matter which way these are installed. Install the two capacitors where designated by 'C2' and 'C3'.
 
4. The next component to look for is a small capacitor like C2 and C3 except that this one is a 5pF capacitor and is marked with a '5'. Install this capacitor where designated by 'C4'.
5. Next, find the resistor networks. A resistor network looks like a comb for a 'Barbie Doll'. On the resistor network (Rnet), there is a dot printed near one end to signify at which end Pin 1 is located. Find Pin 1 on the Rnet and correlate it to the square pad on the PCB that pertains to the 'RN1' part designator. Install the Rnets where designated by 'RN1' and 'RN2'.
 
6. The IC sockets are next in line. Nearly all ICs have a 'Pin 1' marker that denotes the location of Pin 1. It is important to install chips with the proper orientation since, more often than not, installing a chip backwards will result in damage to the chip and/or surrounding circuitry. For the IC sockets that you will be installing, there is a notch on the edge of one of the short sides. This notch denotes the 'top' of the chip. When oriented properly, Pin 1 is the top-left pin as depicted in the drawing to the right. Install both the 28-Pin and the 8-Pin DIP sockets into U1 and U2 respectively.
 

7. The next component to install is the ceramic resonator. The ceramic resonator looks like a coffee bean (although sometimes they are blue instead of brown) with three metal legs sticking out from one side and should be marked as "50.00" (50 MHz). This component is 'polarity insensitive'. That is to say that it doesn't matter which way it is installed, it will still work OK. Install the ceramic resonator where the 'XTAL' designator is.

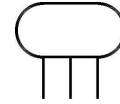

8. Next, grab the electrolytic capacitor. It resembles a small cylinder with two long legs emerging from one end. Be particularly careful when installing this component. If it is installed backwards, it can pop like a miniature fire cracker and emit a horrible stench after it is powered up. The electrolytic capacitor will have the negative lead marked with one or more '-' signs. Install the leg NOT marked with the '-' signs in the hole closest to the '+' sign in C1's space on the pcb.

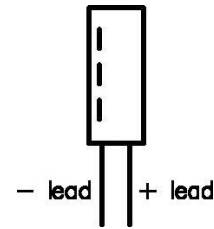

9. Now find the PNP transistor (Q3); it looks like a black bead with three legs and bears the mark, "3906". The white silkscreen on the pcb will guide you as to how to orient this component. There are two other components that closely resemble the PNP transistor that you will be installing in this step. Please note that the middle legs must be bent slightly to accommodate the hole patterns for Q1, Q2, and Q3. Please bend the middle leg of the PNP transistor (3906), and the NPN transistors, (3904), as shown in the drawing above. Avoid excessive bending as this can damage the component. Install the PNP transistor into Q3, and the NPN transistors into Q1, and Q2.

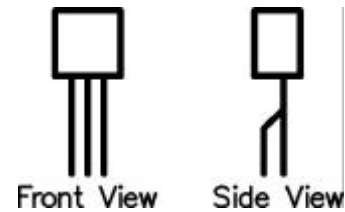

10. Next you will install the 9-pin D-Sub connector. This is the only component that looks like it will plug into a serial cable. Install it on the top side of the pcb.
11. The last component to solder on is the voltage regulator, VR1. It is a relatively large plastic square with a metal tab protruding from the top. Install this with the metal tab closest to the 9-pin D-Sub connector. This component, like the electrolytic capacitor, IS polarity sensitive and MUST be installed correctly, lest ye suffer smoke and fire and the gnashing of teeth.
12. Be sure you clean the board before you stuff the Basic Interpreter IC and the eeprom IC into U1's and U2's respective sockets. That's it ! You've done it! You've made your own stamp.
13. Visually inspect the board. Before applying power to it, repair any and all soldering errors and verify that all components have been installed in the proper locations and with the correct orientation.
14. Download and run the latest version of the program, STAMPW.exe, from either the CD or the website. Connect the OEM BS2sx to a PC serial port and power it up. Please consult the Basic Stamp manual, also available from either the CD or our website, for guidance on using your BS2sx. Please select the BS2sx as the default stamp before attempting to identify or download a program to your new BS2sx. You must also name the stamp program you wish to download with a .bsx extension.

OEM BS2sx – Rev A Design Notes

One of the main purposes behind the OEM BS2sx is making it easier to embed a BS2sx into an OEM design. When designing the BS2sx into an your product, please consider the following:

- **Power Supply** - The Basic Interpreter requires a 'clean' 5 Vdc supply. The LM2940 was selected because of its wide operating range, built-in protection features, and ability to deliver a lot of current. The value of the output capacitor, C1, was based on the manufacturer's recommendation. Be sure to consult the manufacturer's recommendations for input and output capacitance selection for the regulator that you will be using in your design. Also, if the Basic Interpreter will be located more than a couple of inches away from the power supply, it may be a good idea to add a 0.1 uF ceramic capacitor across Vdd and Vss at the Basic Interpreter IC.
- **Resonator Location** – Note that the resonator on the OEM BS2sx board is located adjacent to the Basic Interpreter. When laying out your board, please choose a location for the resonator that is as close as possible to the Basic Interpreter, and has the shortest circuit traces possible to ensure reliable operation.
- **Regulatory Warnings** – Stamps and their constituent components are not FCC approved. They are not in finished product form. If you wish to obtain FCC approval, you must first design the stamp into a product, then seek FCC approval of the whole product.

